

1

2

3

4

REV	Description	
-01	Initial revision	AL/VG
-02	1. Changed U1 from PTN3363BSMP to PTN3365BSMP. 2. Added external ESD protection diode ( D2 , D3 ). 3. Added resistor R14 and capacitor C20 for HDMI connector J2 . 4. Added assembly option (default: not assembled) capacitor ( C23 , C24 , C25 , C26 ). 5. Set capacitor ( C15 , C16 , C17 , C18 , C19 ) to not assembled. 6. Added J4 CSI-2 Camera connector.	ED

A

A

B

B

C

C

D

D

Title: <b>CR00240 - Revision History</b>			Design licensed from MicroFPGA UG(h)
A4	Number: <b>CR00240</b> A	Rev. <b>02</b>	
Date: 04.12.2025	Copyright: Trenz Electronic GmbH	Page 1 of 4	
Filename: <b>Revision Changes.SchDoc</b>			

1

2

3

4

Special notes:

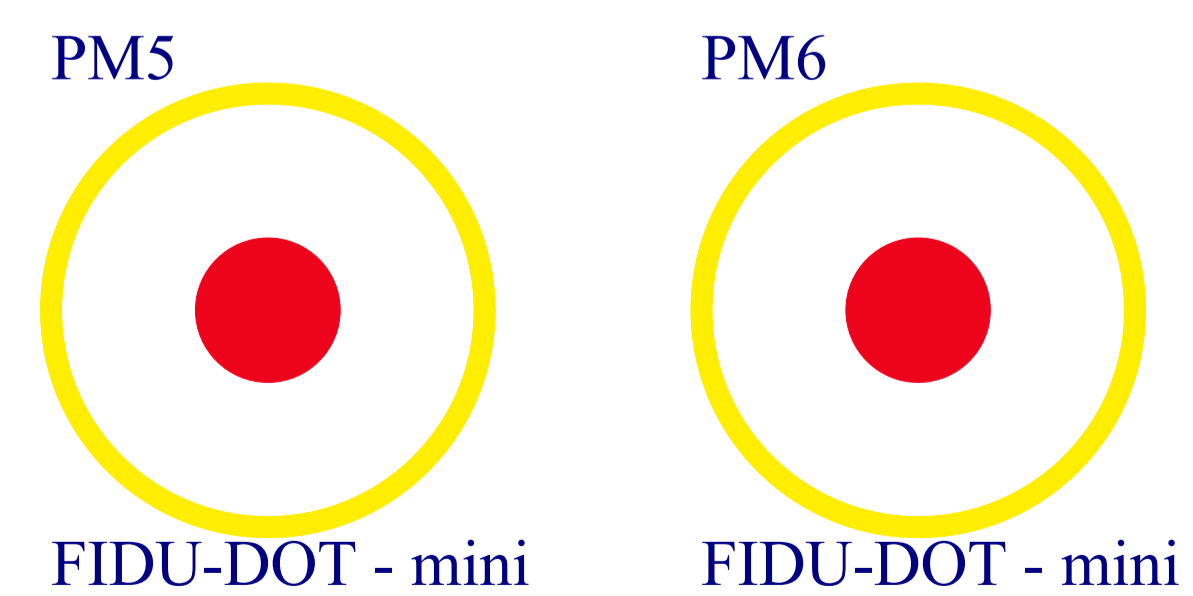
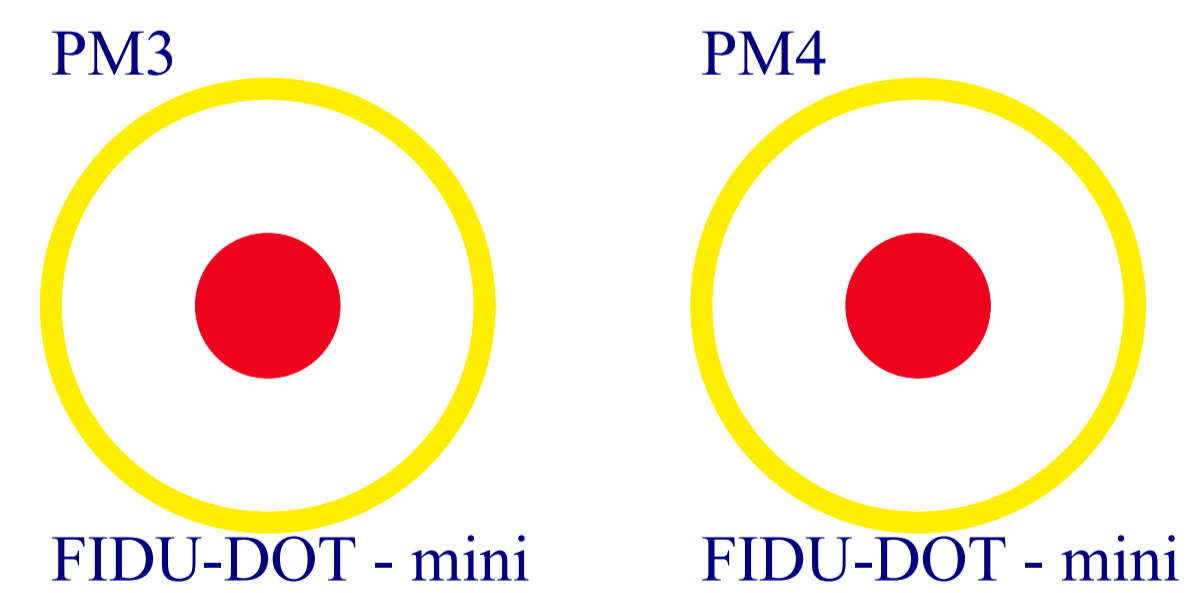
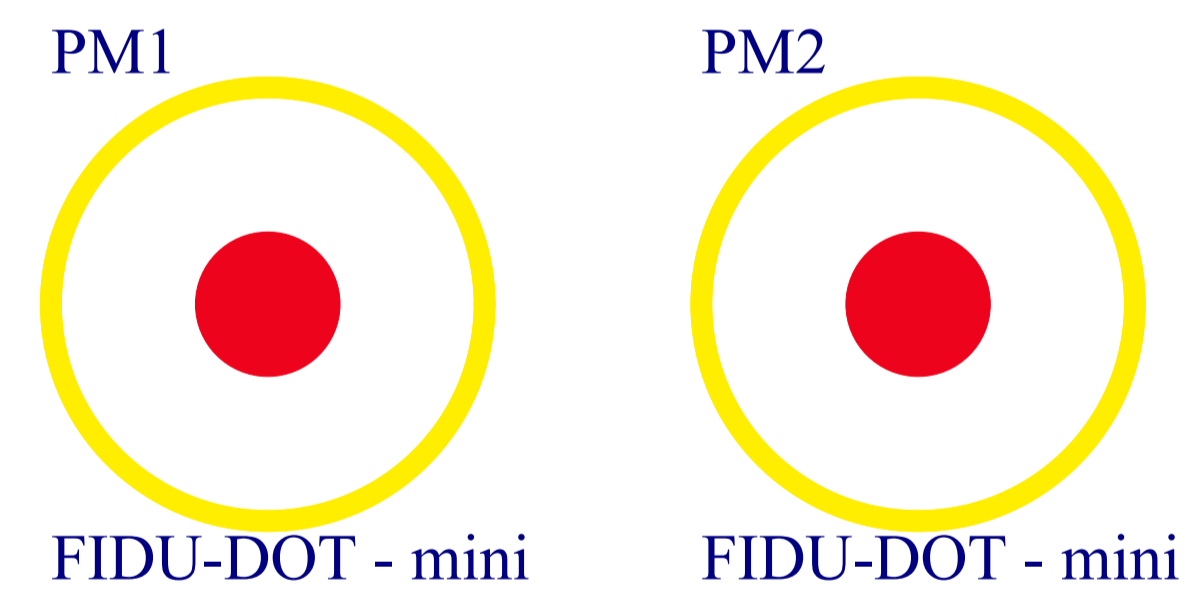
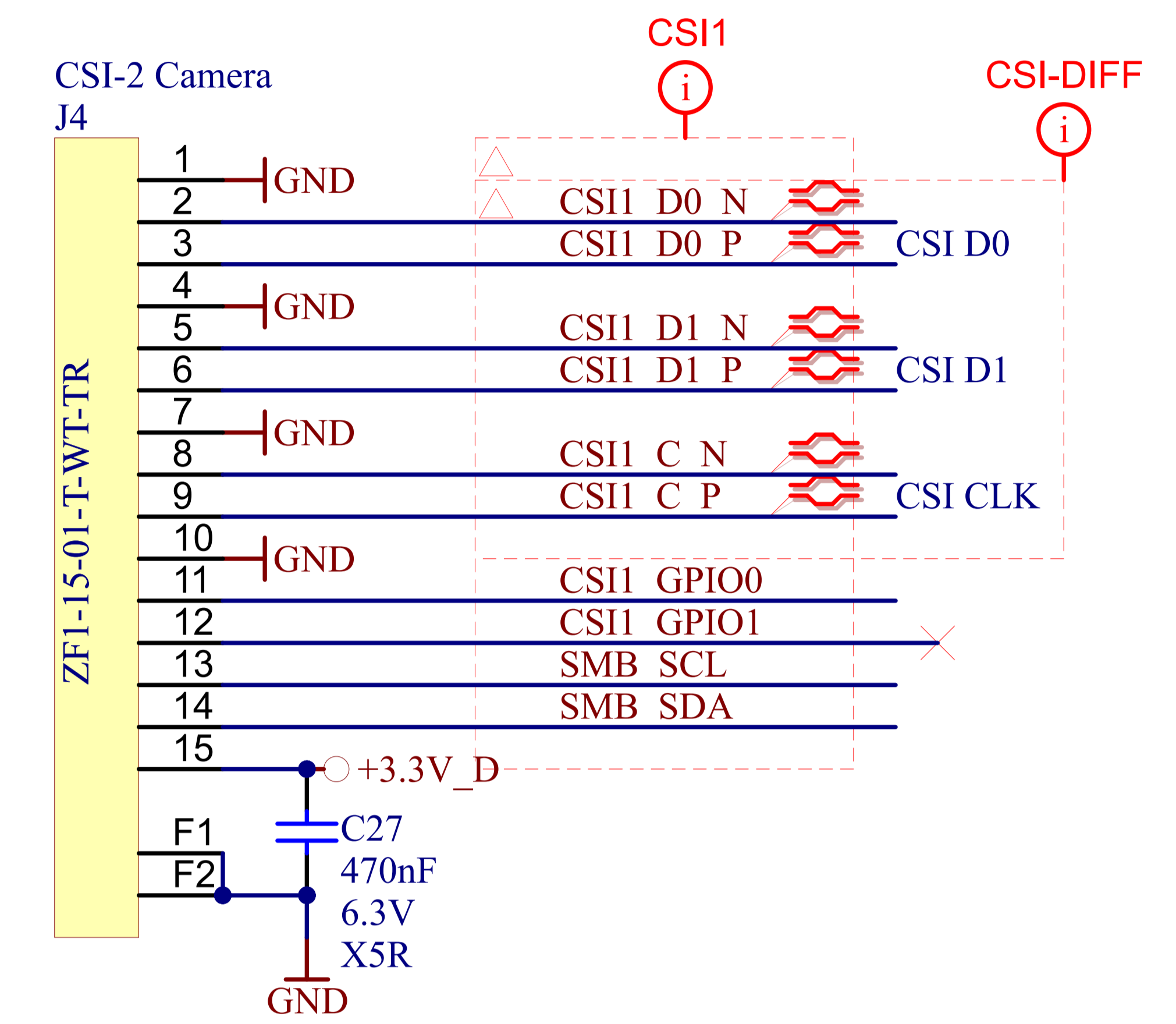
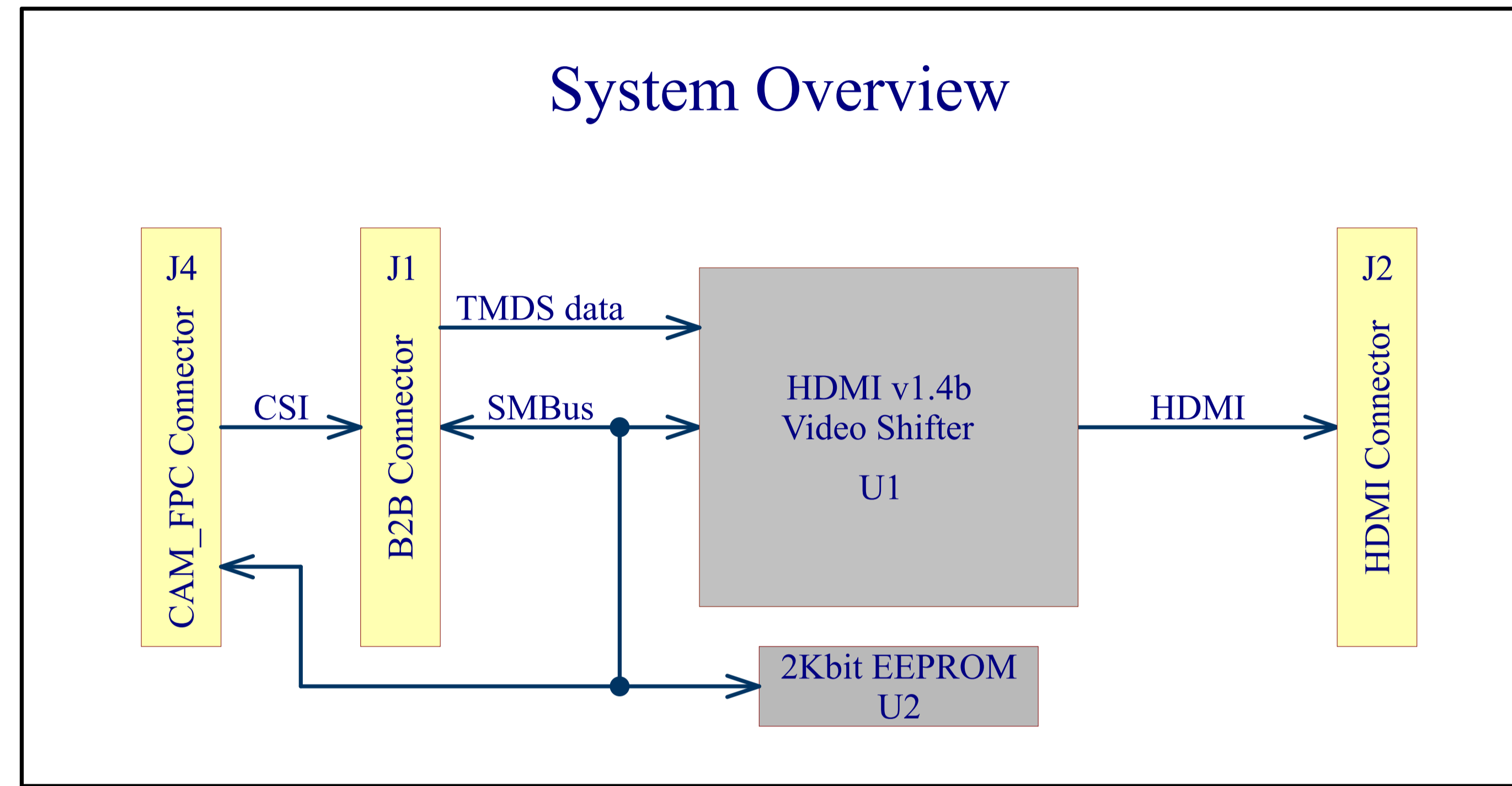

Serial1  
Serial  
Serialnumber 6,3 x 6.3mm

LOGO1  
TE Logo PRINT Layer  
LOGO PRINT

CE  
CE Logo on Top Overlay  
CE-TOOVERLAY

RoHS  
RoHS Logo on Top Overlay  
RoHS-TOOVERLAY

WEEE  
WEEE Logo on Top Overlay  
WEEE-TOOVERLAY

Drawn by	ED
Checked by	
Assembly variant	A
Created by	ED
Modified by	ED
Modified at	2025-08-01

Title: CR00240		Design licensed from MicroFPGA UG(h)	
A4	Number: CR00240 A	Rev. 02	
Date: 20.10.2025	Copyright: Trenz Electronic GmbH	Page 2 of 4	
Filename: CR00240.SchDoc			

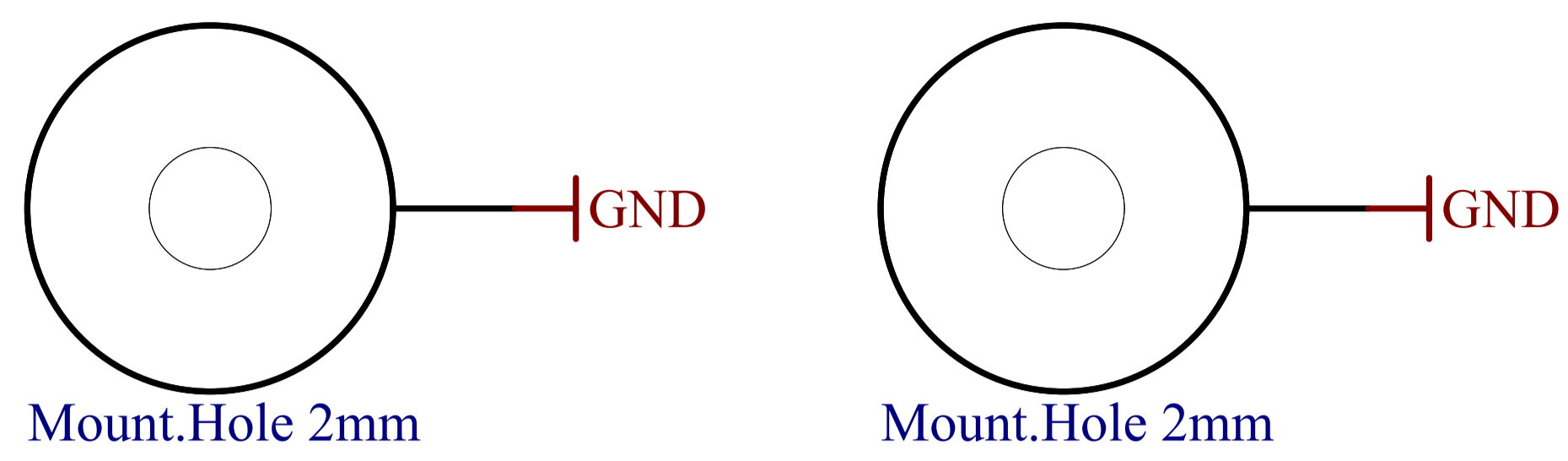

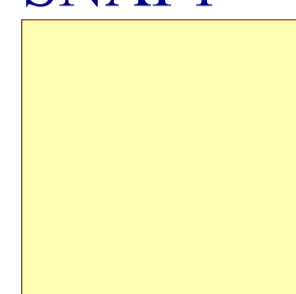
SNAP1  
  
 SNAP CRUVI 3x

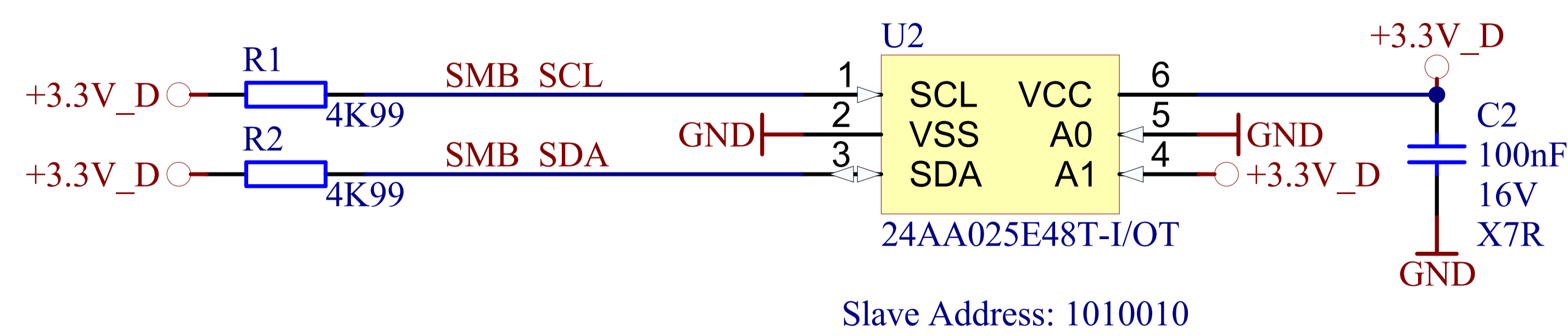
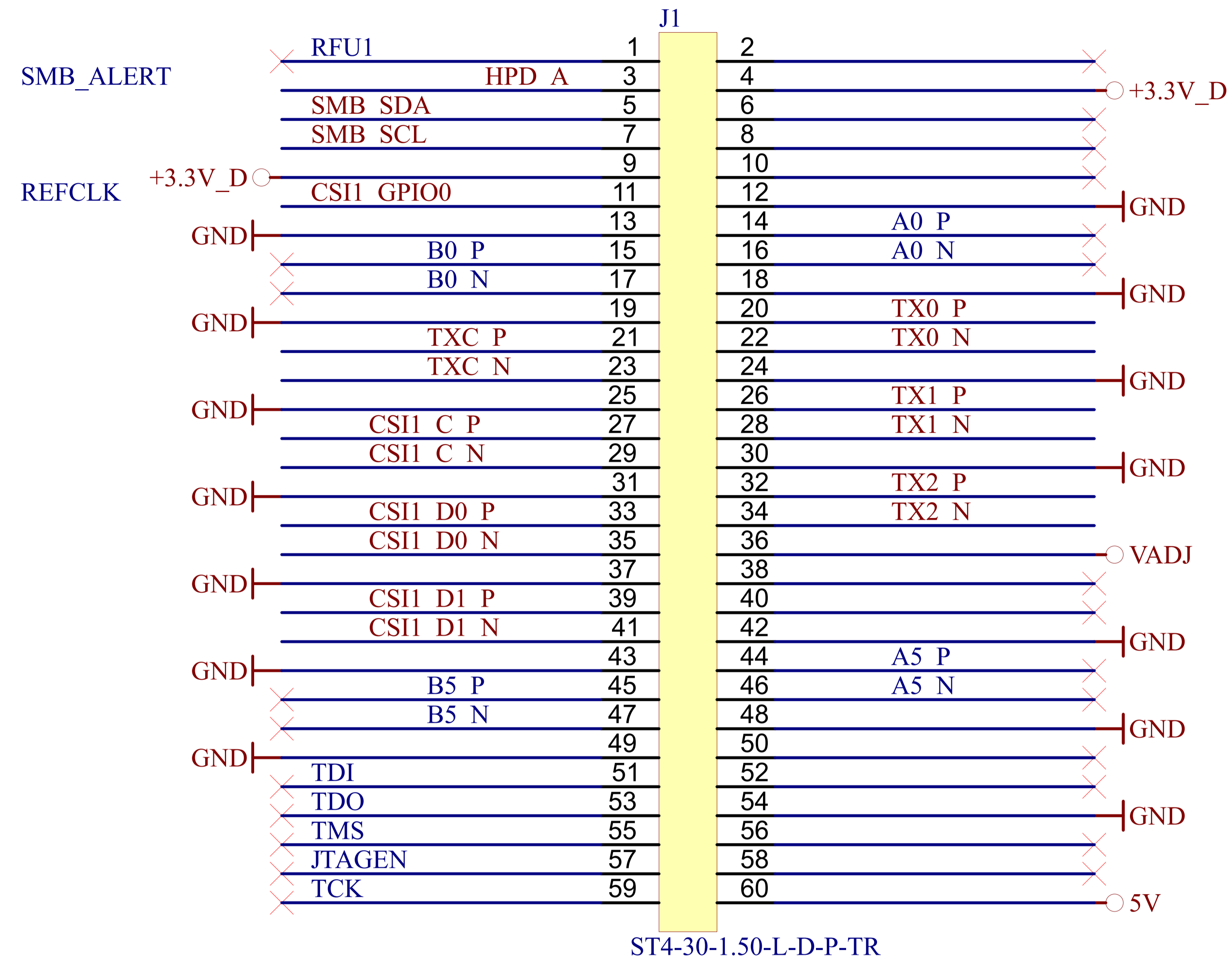

Title: <b>CR00240 - Connector</b>			Design licensed from MicroFPGA UG(h)
A4	Number: <b>CR00240</b> A	Rev. <b>02</b>	
Date: 20.10.2025	Copyright: Trenz Electronic GmbH	Page 3 of 4	
Filename: <b>CRUVI.SchDoc</b>			

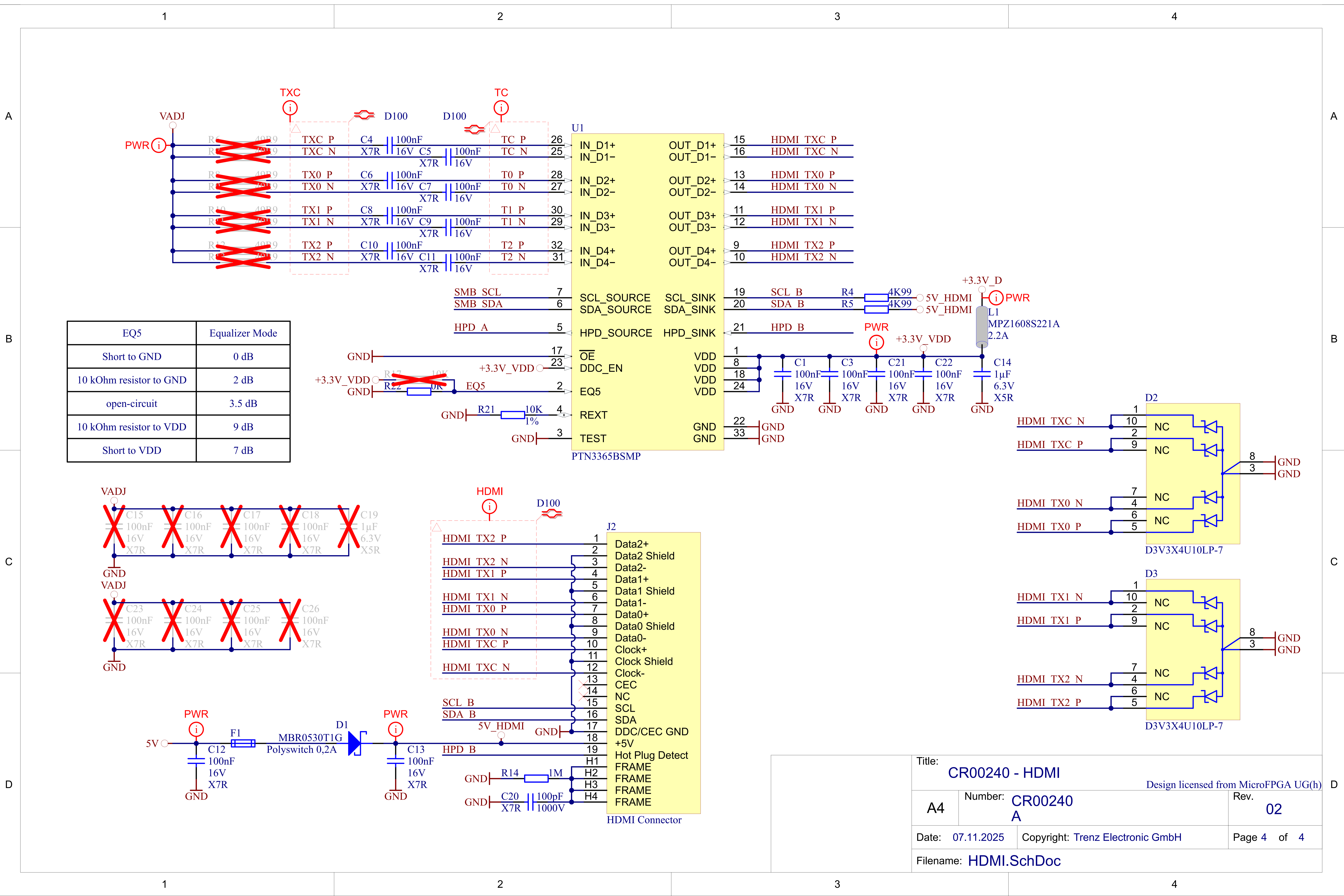

EQ5	Equalizer Mode
Short to GND	0 dB
10 kOhm resistor to GND	2 dB
open-circuit	3.5 dB
10 kOhm resistor to VDD	9 dB
Short to VDD	7 dB

Title: **CR00240 - HDMI**  
 Design licensed from MicroFPGA UG(h)

A4	Number: <b>CR00240</b> A	Rev. <b>02</b>
Date: 07.11.2025	Copyright: Trenz Electronic GmbH	Page 4 of 4

Filename: **HDMI.SchDoc**